



SKYLO

AIR CONCEALED TOILET CISTERN



WARNING

We shall not be responsible or liable for any failure of, or damage to, this plumbing product caused by the use of chlorine/bleach cleaners or related products added to the tank water. Use of such products will void the warranty and may result in product failure, possibly causing property damage. Do not over tighten plastic nuts and always turn off water supply when installing / removing toilet cistern parts.

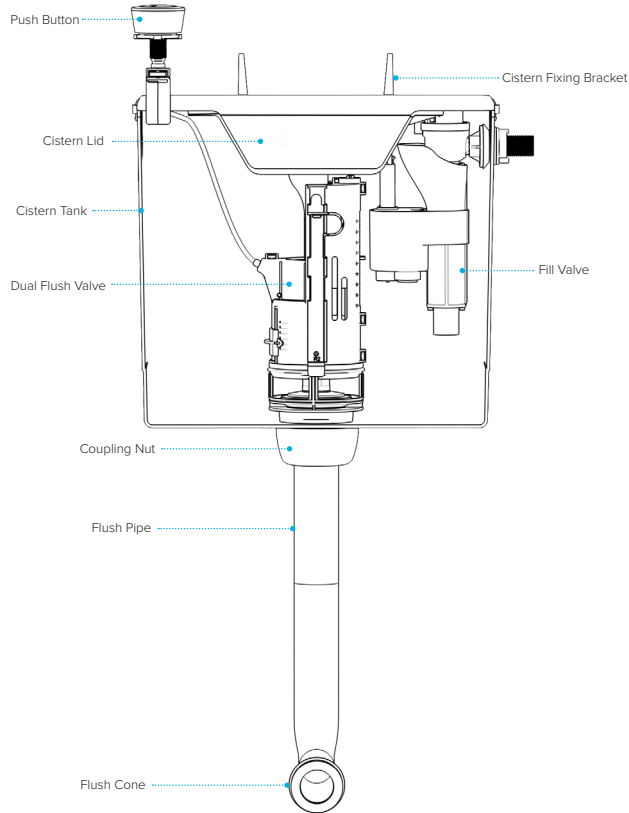

PRE INSTALLATION CHECKS AND NOTES

- 1 First check for any obvious manufacturing defects i.e. Cracks.
- 2 Check all parts listed are present.
- 3 Follow installation guide carefully.
- 4 Pressure to the cistern should preferably be between 0.2 bar and 8.0 bar, if greater, it is recommended that an inline pressure reducing valve is fitted.
- 5 An isolation valve is required before the cistern so the tank can be isolated from the mains for maintenance.
- 6 Pipework must be free from debris prior installation.
- 7 Do not use plumbers putty or silicone sealant on any fittings.
- 8 Ensure the mounted surface is adequate to carry the weight of the cistern when full approx 8kg.

WARRANTY EXCLUSIONS

- 1 Faults that occur due to working outside the recommended pressure
- 2 Damage found to be caused at site.
- 3 Damage caused by bleach/cleaners. It is not recommended any in tank cleaners are used as they may result in product failure and/or property damage.
- 4 Faults caused by incorrect or poor installation.
- 5 Faults caused by any other particles, dirt, silt, silicone, plumbers putty etc.

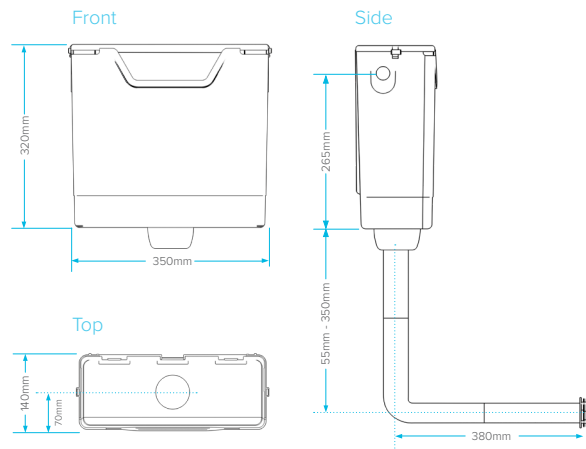

PART 1: INSTALLATION OF CISTERN FITTINGS

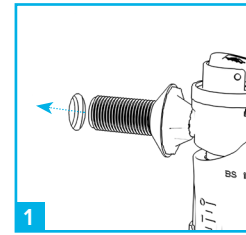

1 Remove the plastic washer and nut from the thread and place the valve into the desired hole in the cistern ensuring the conical rubber seal sits evenly inside the hole.

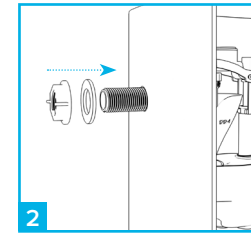

2 Secure the valve to the cistern by replacing the plastic washer and screwing the nut to the thread. Do not over tighten.

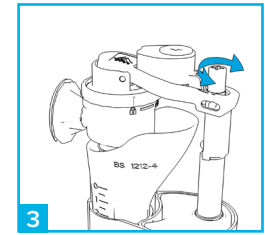

3 Set the lifted float to the same height as the 6L mark on the cistern by turning the adjustment screw (clockwise for more water and anticlockwise for less water).

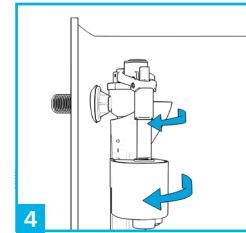

4 Rotate the float to the desired location.

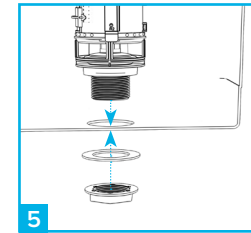

5 Insert the flush valve into the cistern and tighten using the washer and nut.

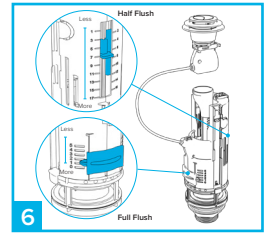

6 The flush volumes of both the full and half flush can be adjusted to suit your requirements. The flush valve is factory set to full flush and a half flush of 3L.

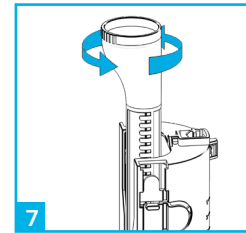

7 To adjust the overflow tube height, turn tube anticlockwise and adjust up or down, we recommend setting the tube to 8.

UK - Units 1-3 Capitol Trading Park, Kirkby Bank Road, Knowsley Industrial Estate, Liverpool, L33 7SY
EU - Authorised Rep Compliance Ltd., GroundFloor, 71 Lower Baggot Street, Dublin, D02 P593, Ireland.

For more information please contact us:
Tel: 0151 546 0531 E-mail: sales@vivasanitary.co.uk

Please note: Save this instruction sheet for future reference
IMPORTANT: DO NOT use plumber's putty to seal this fitting

PART 2: CISTERN AND FIXING BRACKET

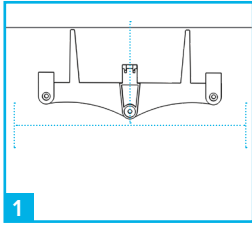

Position and fix the support bracket in the centre of the unit or in line with the WC waste outlet. The guide tabs should be level and underneath the top of the unit. This allows ample clearance for lid to be removed and parts to be accessed.

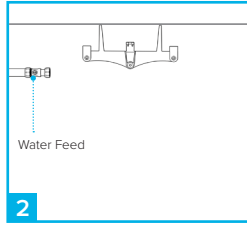

Plumbing connections should be in place prior to cistern being hung.

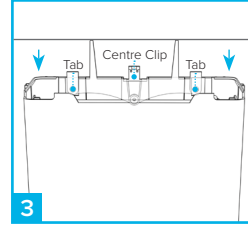

To hang the cistern, ensure the bracket is firmly fixed, slowly lower the cistern holding it centrally to the bracket. Ensure the tabs are aligned with the recesses in the cisterns, push down until cistern clicks into place.

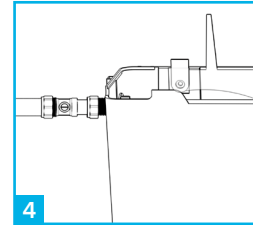

Complete the plumbing connections as required. It is recommended this is done by a fully qualified plumber.

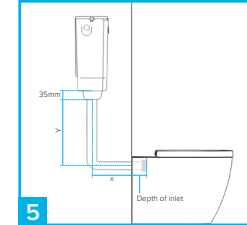

Position the WC pan, and check measurements for the flush pipe. Cut the flush pipe to size if required. It is important to remember that 35mm needs to be inserted into flush valve thread and again a certain amount depending on WC pan needs to project into toilet inlet.

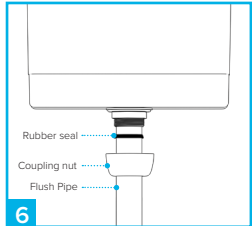

Once cut to size, connect the flush pipe to cistern using rubber seal and connection nut and fit the flush cone onto narrow end of the flush pipe.

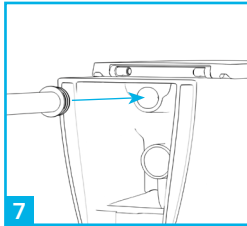

With the toilet pan in position push to flush cone into the WC toilet inlet

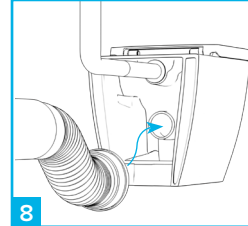

Make waste connections to toilet pan spigot, as per WC pan guidelines. (For back to wall toilet pans, we recommend using a VIVA flexible pan connector).

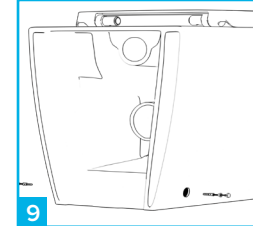

Double check all connections, i.e. water feed to inlet connection, flush valve to flush pipe connection, flush pipe to pan connection and pan spigot to waste connection. Once happy they are all water tight, tighten and secure WC pan.

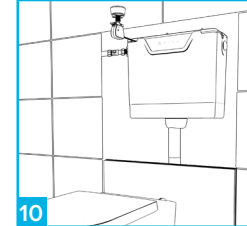

Please remember if cistern is behind a permanent construction, access will be required for future maintenance.



UK - Units 1-3 Capitol Trading Park,
Kirkby Bank Road,
Knowsley Industrial Estate, Liverpool,
L33 7SY

EU - Authorised Rep Compliance Ltd.,
GroundFloor,
71 Lower Baggot Street, Dublin, D02
P593, Ireland.

For more information please contact us:
Tel: 0151 546 0531
E-mail: sales@vivasanitary.co.uk

PART 3: COMPLETE INSTALLATION & FINAL CHECKS

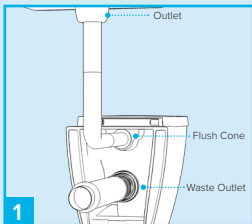

Once all connections are made turn on the water. Check for any obvious leaks.

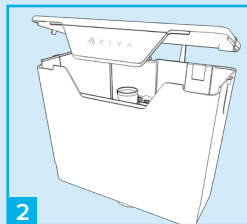

Place lid onto cistern.

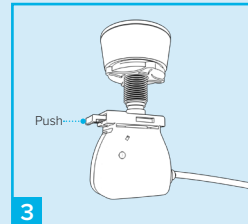

When connecting the button it is very important when deciding on the position that the cable runs smoothly, this prevents valve failure. Once the position of the button is decided fix into position as shown. Please note the hole size for the button is 40mm.